



DW-HL1.8



Stirling Refrigeration

The inner temperature of the refrigerator is within $-86^{\circ}\text{C} \pm 1.5^{\circ}\text{C}$ which is precise and stable, and the display accuracy can reach 0.1°C .

MINI The Smallest Volume In The Industry

It can be placed on experiment table, and can use DC12/24V vehicle power supply or AC100V-240V household power supply.

Humanization Design

The body of freezer is made of high-quality structural sheet steel. The head cover has pulling out lifting yoke and the inner part is equipped with refrigeration sheets of various specifications which make it convenient for experimental samples to be cooled directly.



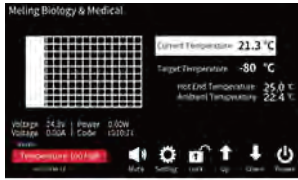

High-precision Temperature Control

- It has the high definition touch screen display with the display accuracy reaching 0.1°C.
- The inner temperature of the inner part can be changed from -40°C to -86°C.
- It is easy to operate with friendly interface and clear operating condition.

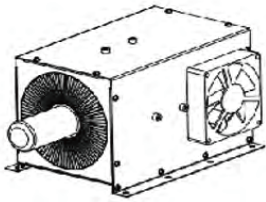

Refrigeration System

- It uses new refrigeration which can refrigerate quick and is energy-efficient without using fluorine-containing freezing medium.
- It has small size and is easy to carry which can use DC12/24V vehicle power supply or AC100V-240V household power supply.
- The foaming body and accessory device for heat preservation use soft EVA blind hole foaming materials. It has good heat preservation flexibility and property and flexible shape and has the strong ability to erase strong high frequency noise.



Alarm system

- It has various functions including high temperature alarm, low temperature alarm, sensor failure alarm, main board communication error which can preserve food in a safer way.
- The protection of power-on delay and power-off interval ensure the safety of operation.
- The functions of keyboard lockout system and keyword protection prevent adjusting operation parameters at will.
- The double-locking design makes the sample storage safer.



Human-oriented

- The body of freezer is made of high-quality structural steel plate which has the tiny volume and can be placed directly on the experiment table and is easy to store samples directly.
- It's easy to control and there are lifting yoke on the freezer body for moving.
- The freezer is equipped with refrigeration packs of various specifications which makes it easy for the direct refrigeration of experimental samples.

✓ Scope of Application

Suitable for use in blood banks, hospitals, health and disease prevention systems, research institutions, colleges & universities, the electronic industry, biological engineering, laboratories in colleges & universities, military enterprises, deep-sea fishing companies, etc.

🔗 Performance Data / Cooling Curve

Cooling — Air Temp —

Environment temperature: 25°C
Container: 1.5ml mini-type needle tubing*48
Cooling time: 25°C→-80°C 120min

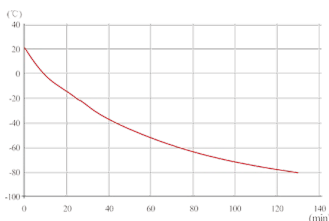

Put in a 1.5ml minitype test tube (water injected) when powering on

Environment temperature: 25°C
Container: 1.5ml mini-type needle tubing*48
Cooling time: 25°C→-80°C 3min

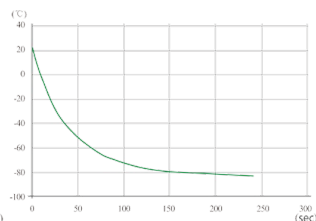

When cabinet running at -80°C, open the lid and put in a 1.5ml minitype test tube (water injected)

📏 External Dimension

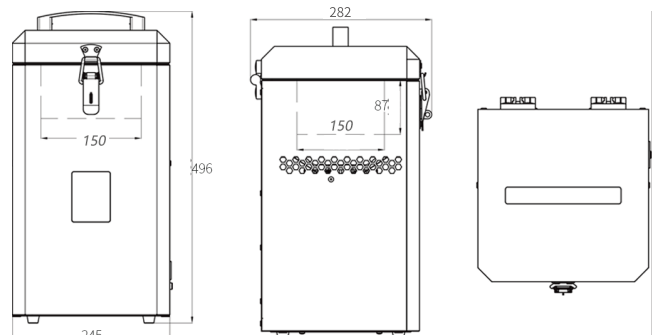

✓ Scope of Application

-86°C Ultra-low Temperature Freezer	
Model	DW-HL1.8
Cabinet Type	Upright
Capacity(L)	1.8
Internal Size(W*D*H)mm	150*150*87
External Size(W*D*H)mm	245*282*496
Package Size(W*D*H)mm	441*372*686
NW/GW(Kgs)	11/25
Performance	
Temperature Range	-40~-86°C
Ambient Temperature	16-32°C
Cooling Performance	-86°C
Climate Class	N
Controller	Microprocessor
Display	Touch Screen
Construction	
External Material	Galvanized Steel Sheet
Inner Material	EVA
Padlock	Yes
Alarm	
Temperature	High/Low temperature
System	Sensor failure, Main board communication error
Electrical	
Power Supply(V/HZ)	DC12/24V, AC100V-240V/50/60
Rated Current(A)	0.46

*The model, parameters and performance specified in this brochure may be changed without prior notice because of product upgrading.

*There may be differences between the product images shown in this brochure and the actual products. When you are buying any product, please check the actual product.

